

XOU Series Air Source Treatment Unit

Overall Dimensions

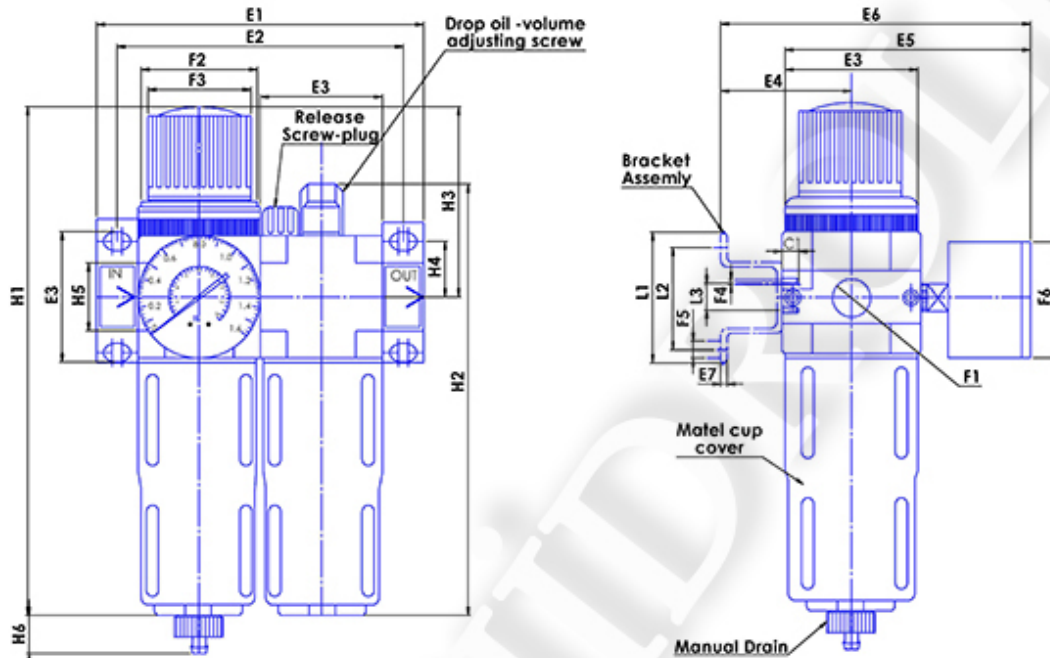
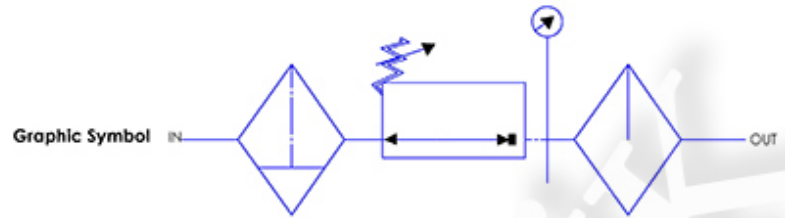

Dimension Sheet

Model	E1	E2	E3	E4	E5	E6	E7	F1	F2
XOU-...MINI	104	92	40	39	76	95	2	G1/8",G1/4",G3/8"	M36x1.5
XOU-...MIDI	140	125	55	47	93	112	3	G1/8",G1/4",G3/8"	M52x1.5
XOU-...MAXI	162,182	146,157	66	53	104	124	3	G3/4",G1"	M36x1.5

MODEL	F3 ϕ	F4	F5 ϕ	F6 ϕ	L1	L2	L3	H1	H2	H3	H4	H5	H6
XOU-...MINI	31	M4	4.5	40	44	35	11	194	169	69	17.5	20	15
XOU-...MIDI	50	M5	5.5	52	71	60	22	250	206	97	24.5	32	15
XOU-...MAXI	31	M5	5.5	63	71	60	22	252	223	80	24.5	32,40	15

Note: The Color Can Be Customized According to Your Requirement

Flow diagram

Standart flow rate q_n as a function of the output pressure p_2

